

MANAGEMENT OF WEB SERVERS
RESULTS OF THE CEO PROJECT

IBM RESEARCH
ZÜRICH
30 SEPTEMBER 1996

Aiko Pras
CTIT
CENTRE FOR TELEMATICS AND INFORMATION TECHNOLOGY
UNIVERSITY OF TWENTE
THE NETHERLANDS

pras@cs.utwente.nl
<http://www.cs.utwente.nl/~pras>
<http://wwwsnmp.cs.utwente.nl/>

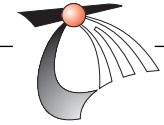

BACKGROUND

JOINT RESEARCH CENTRE (JRC)

- EUROPEAN COMMISSION
- ISPRA - ITALY

CENTRE FOR EARTH OBSERVATION (CEO)

PROVIDERS OF
EARTH OBSERVATION DATA



USERS OF
EARTH OBSERVATION DATA

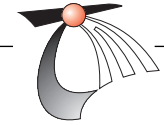

BACKGROUND

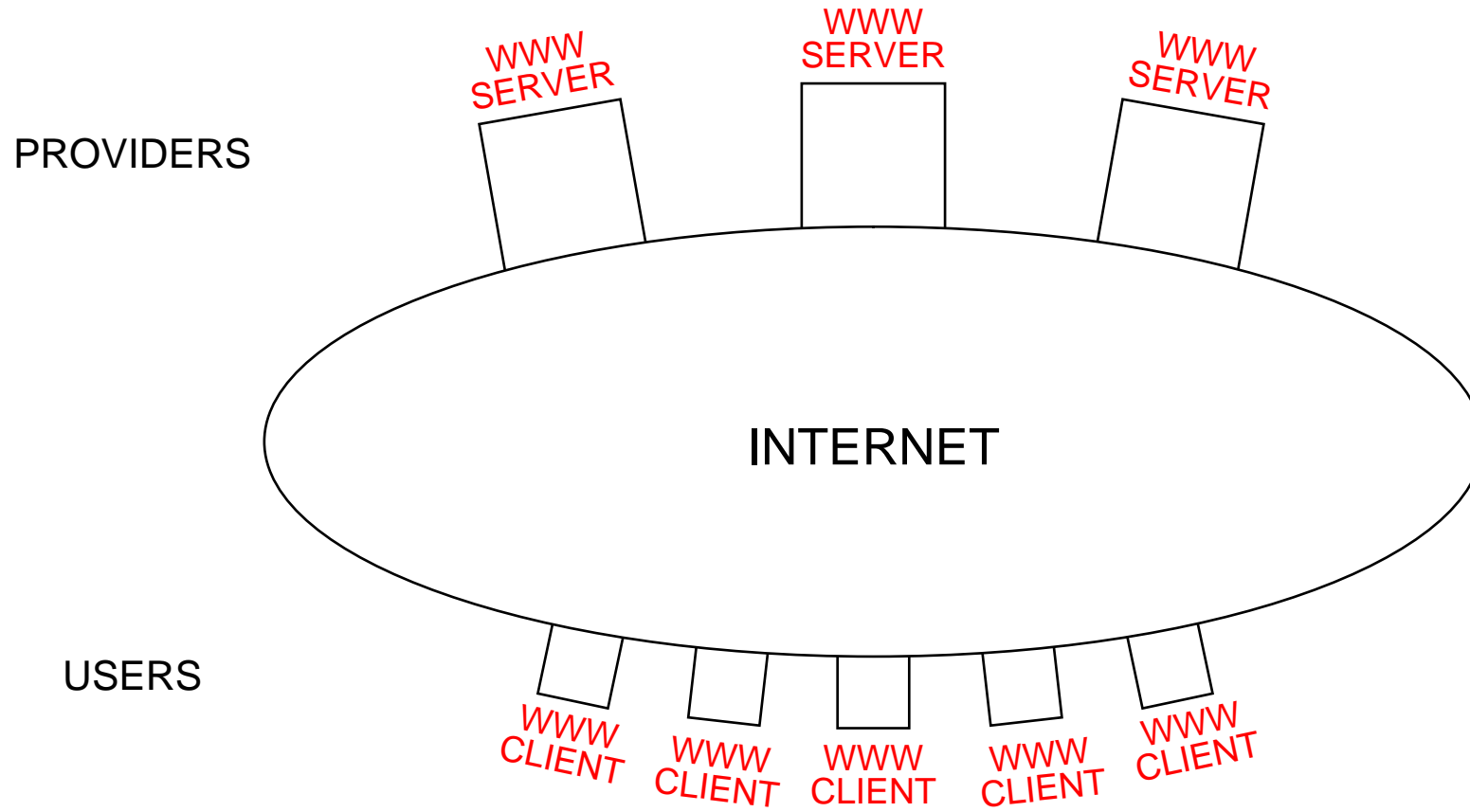

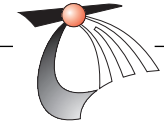

BACKGROUND

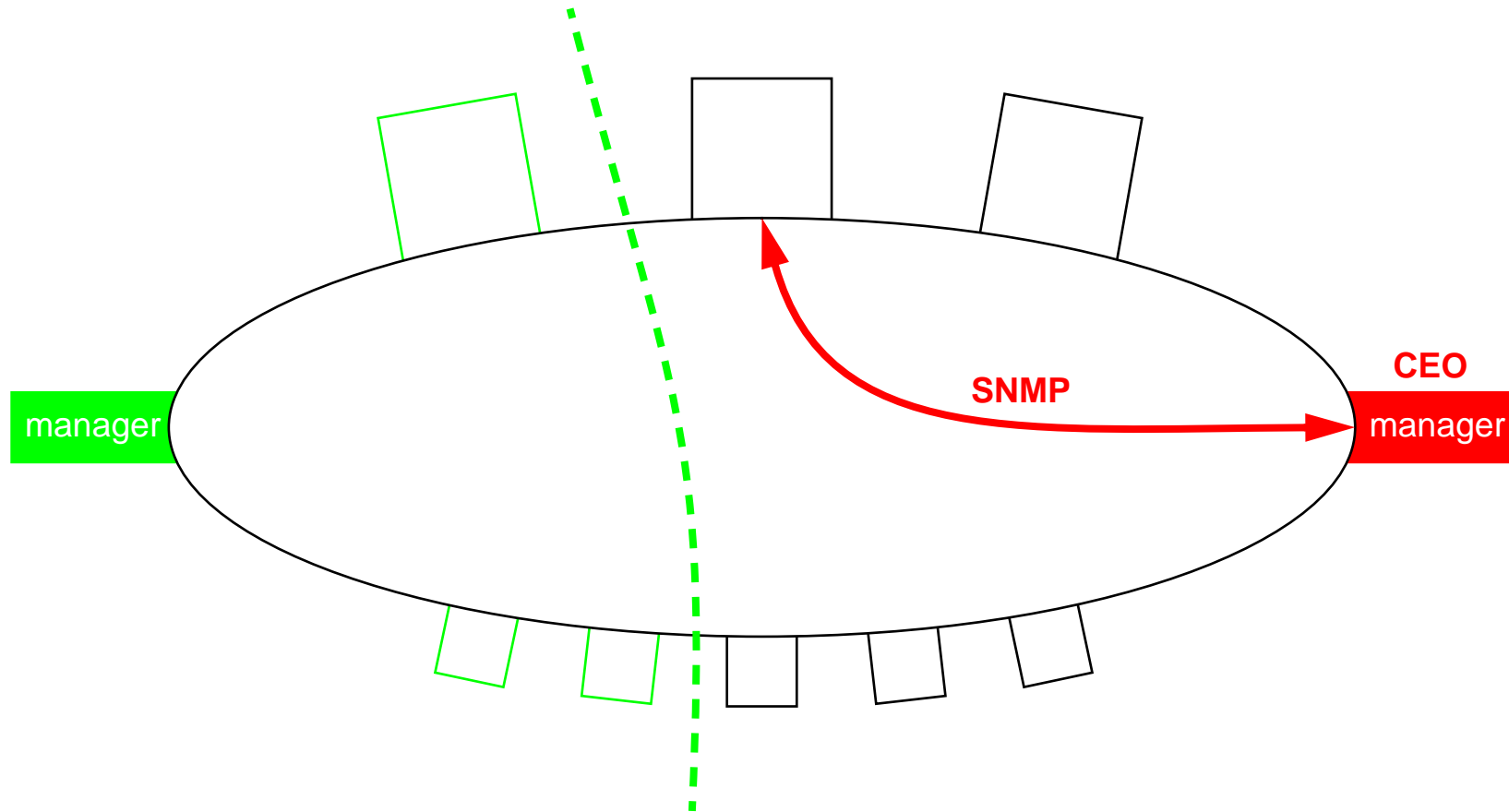

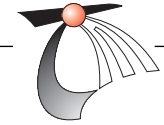

PROOF OF CONCEPT

WWW MANAGEMENT:

- DESIGN AND DEMONSTRATION
 - FIRST PROJECT OF A SERIE

PARTNERS:

- ESYS LTD. - GUILDFORD, UK
 - CTIT - UT, NL
- 9 MONTHS - 120.000 ECU

WORK DIVISION:

- ARCHITECTURE: ESYS & CTIT
 - MANAGER: ESYS
 - AGENT: CTIT

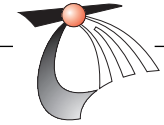

APPROACH

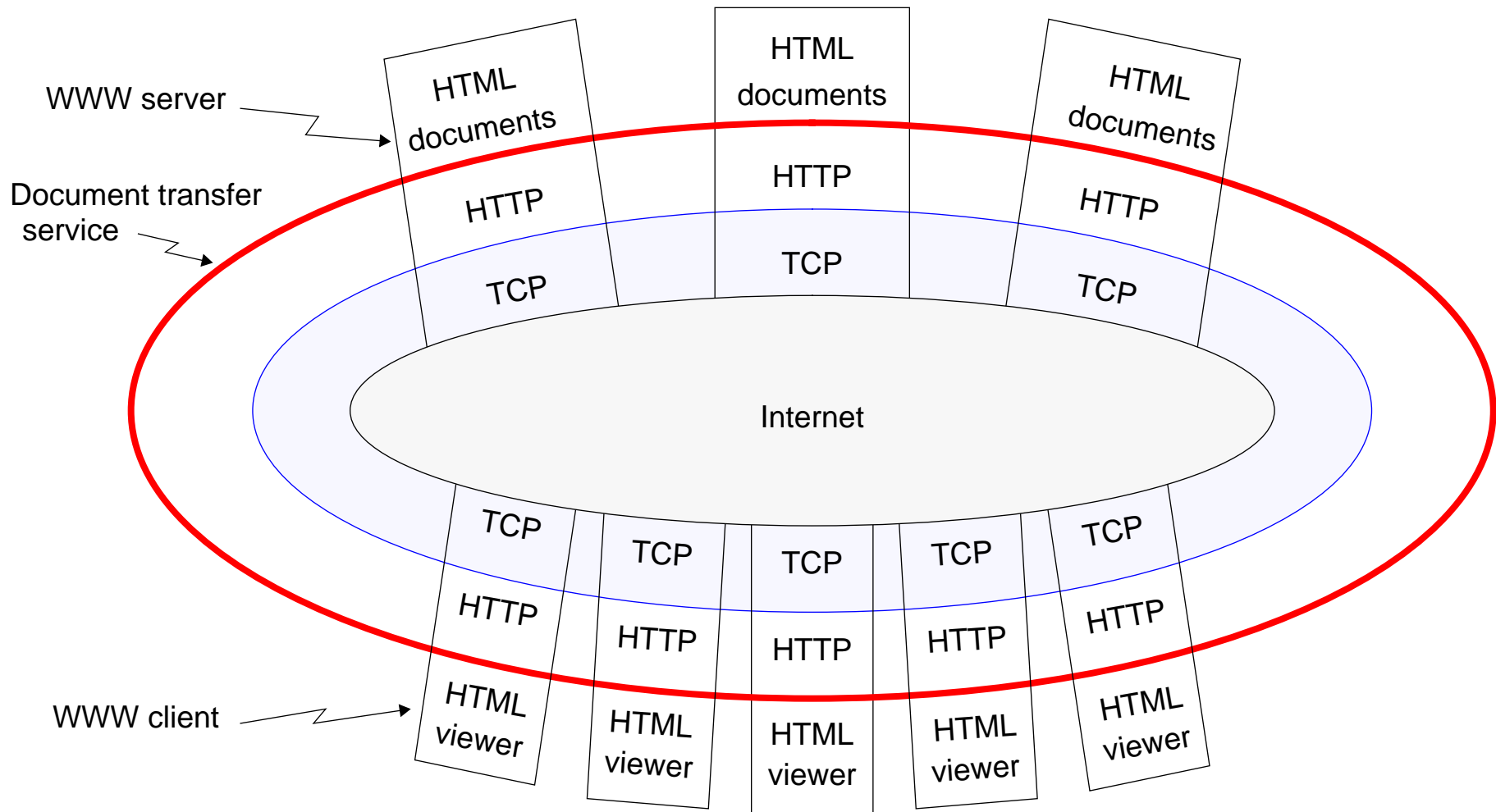

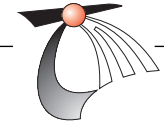

APPROACH

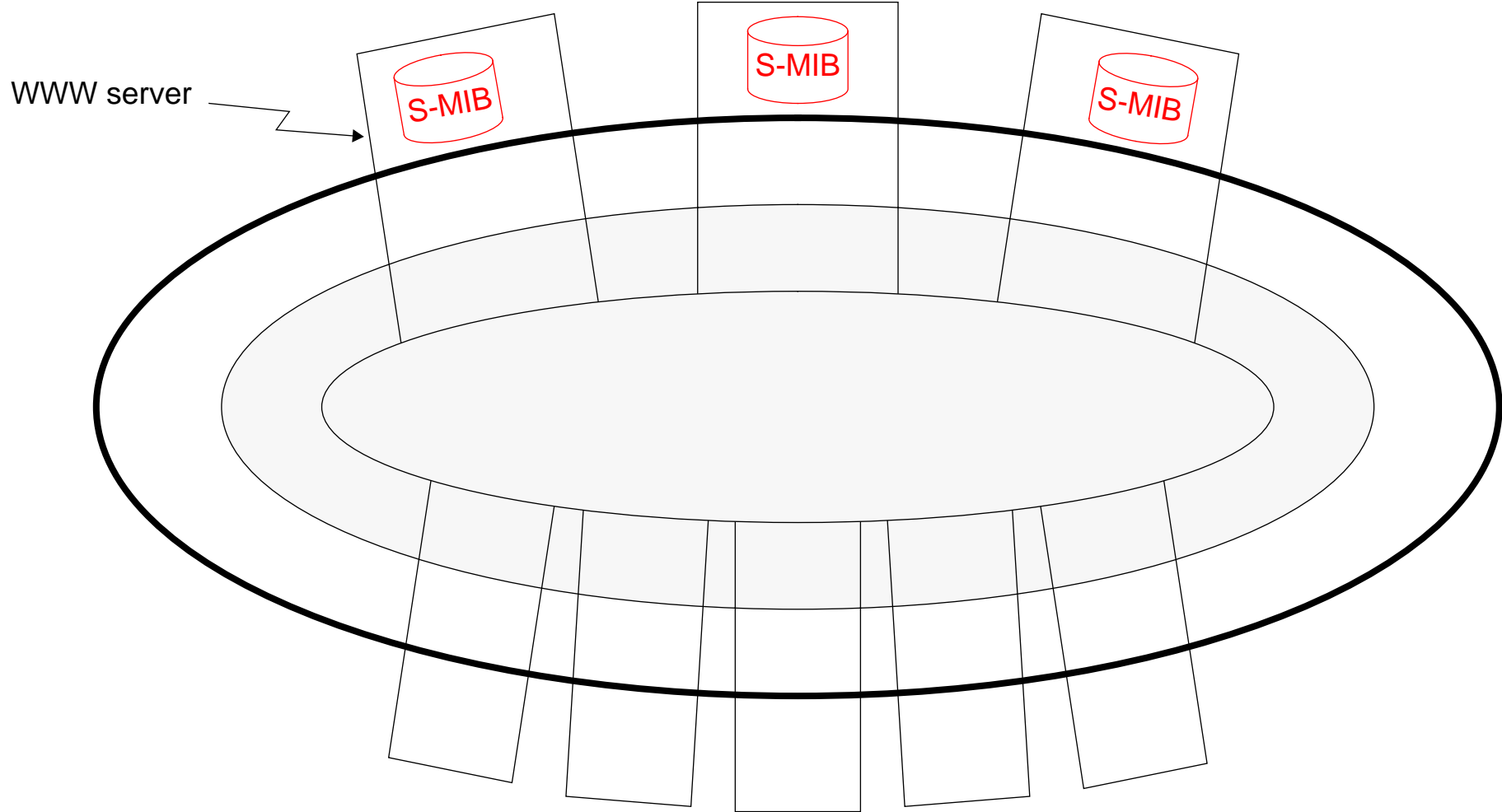

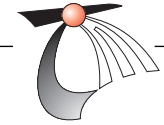

APPROACH

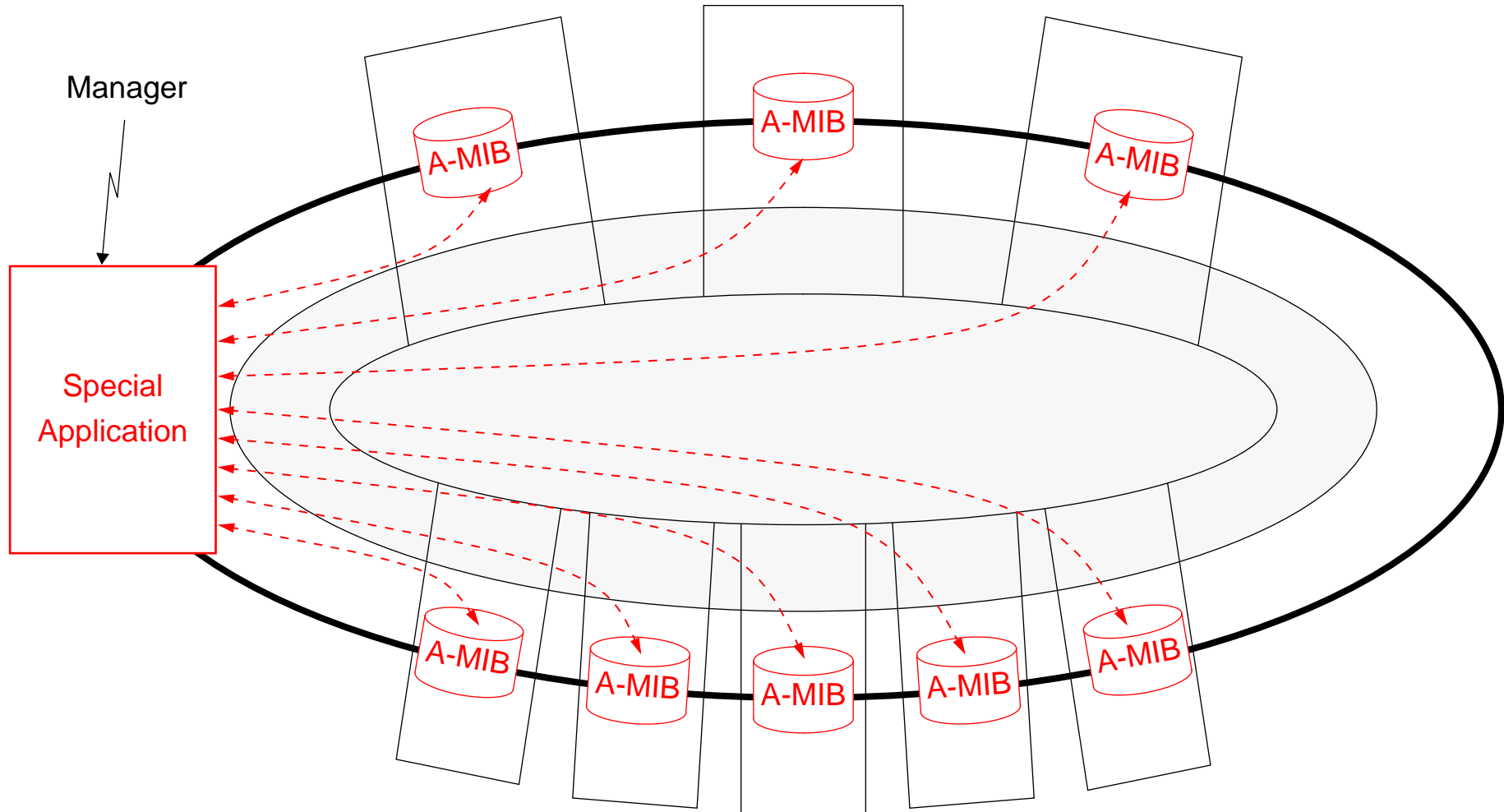

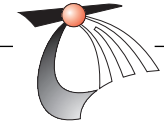

APPROACH

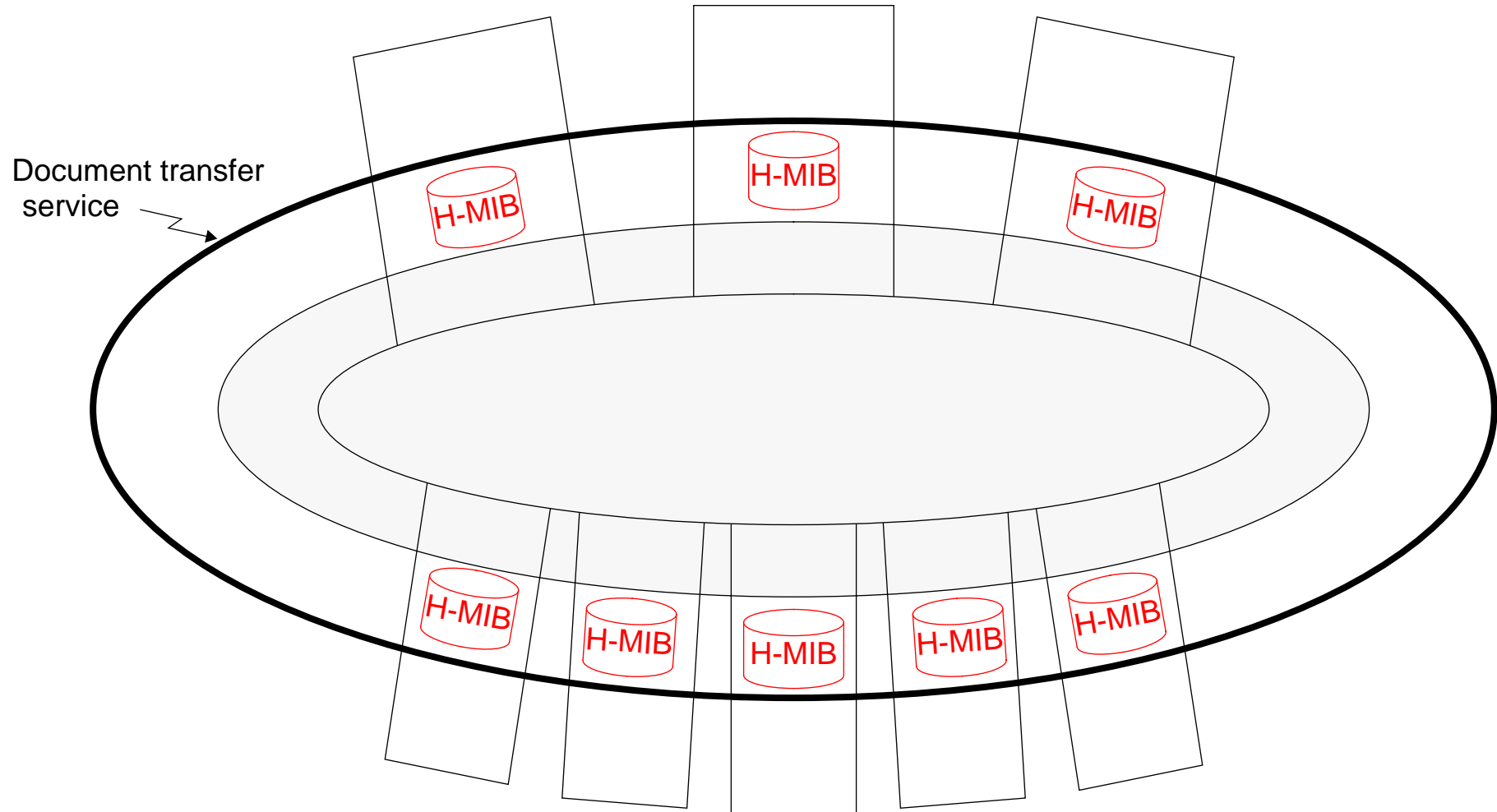

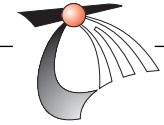

S-MIB

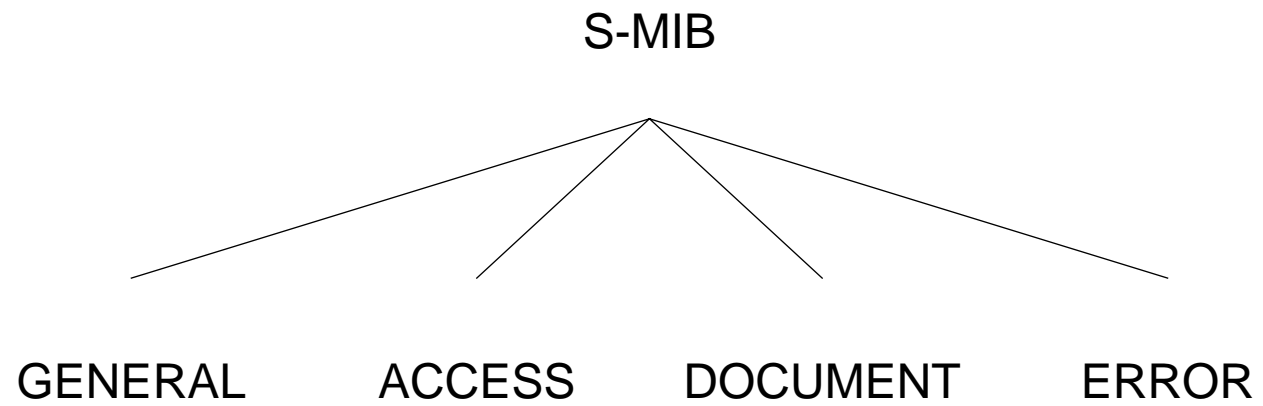

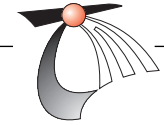

S-MIB

GENERAL INFORMATION

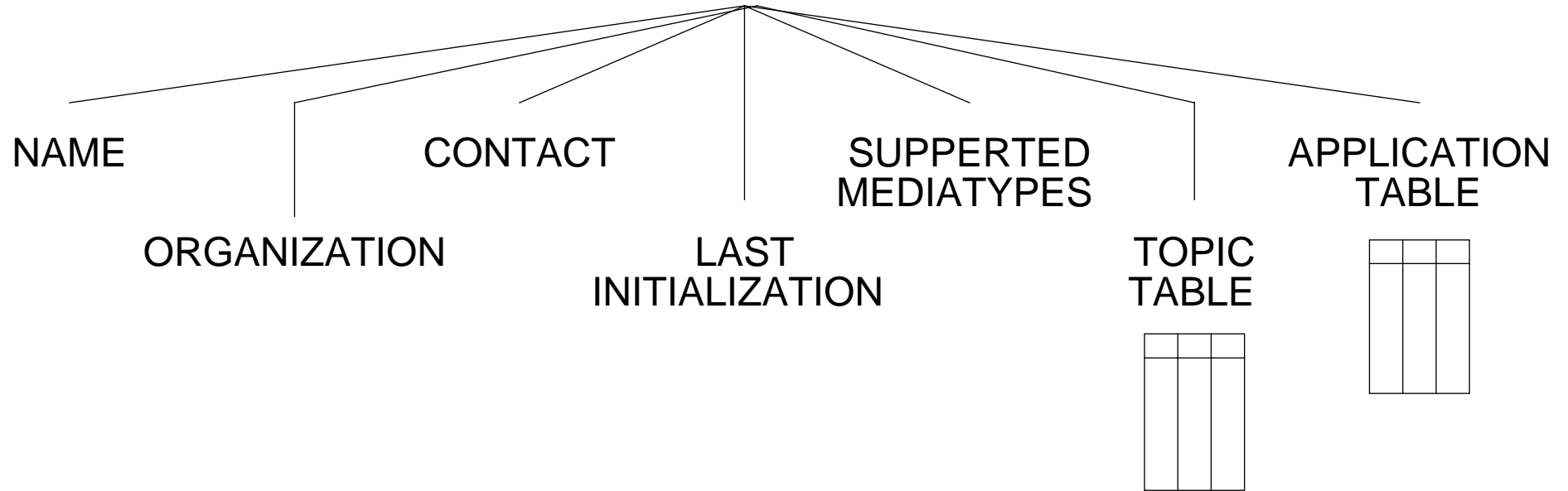

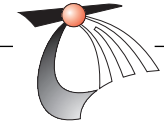

S-MIB

ACCESS INFORMATION

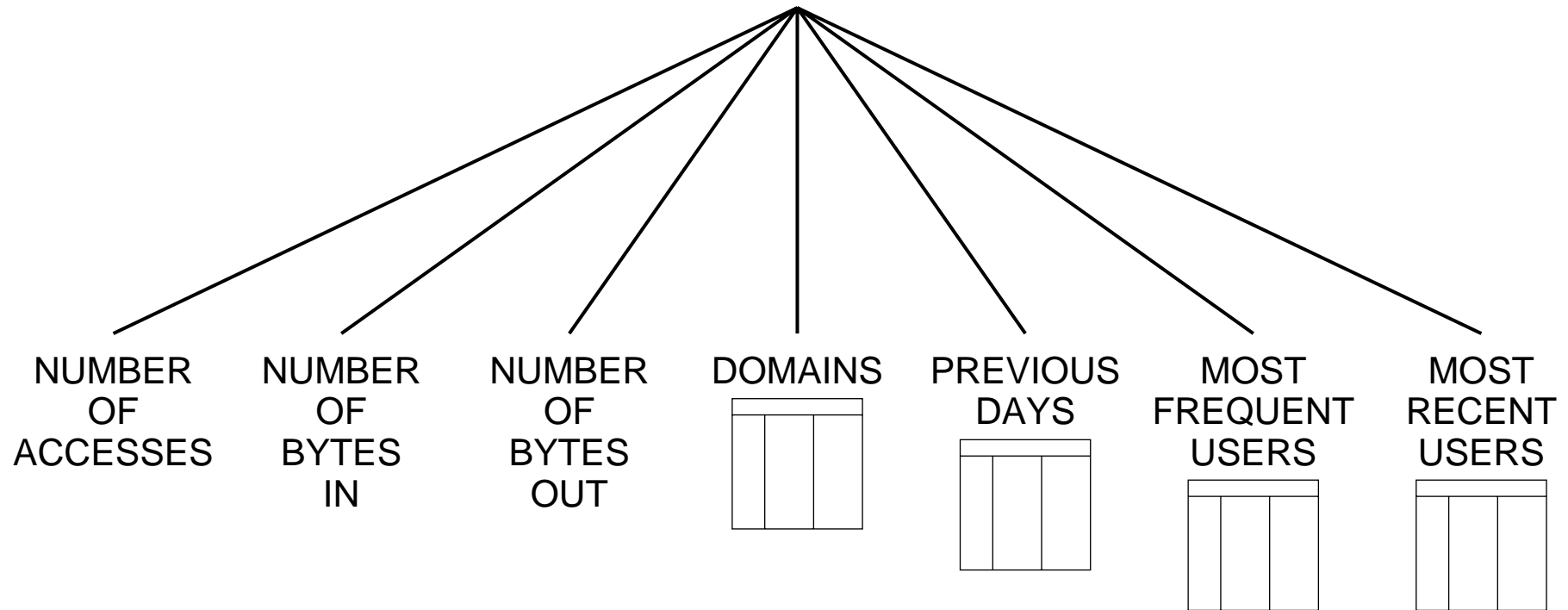

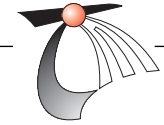

A-MIB

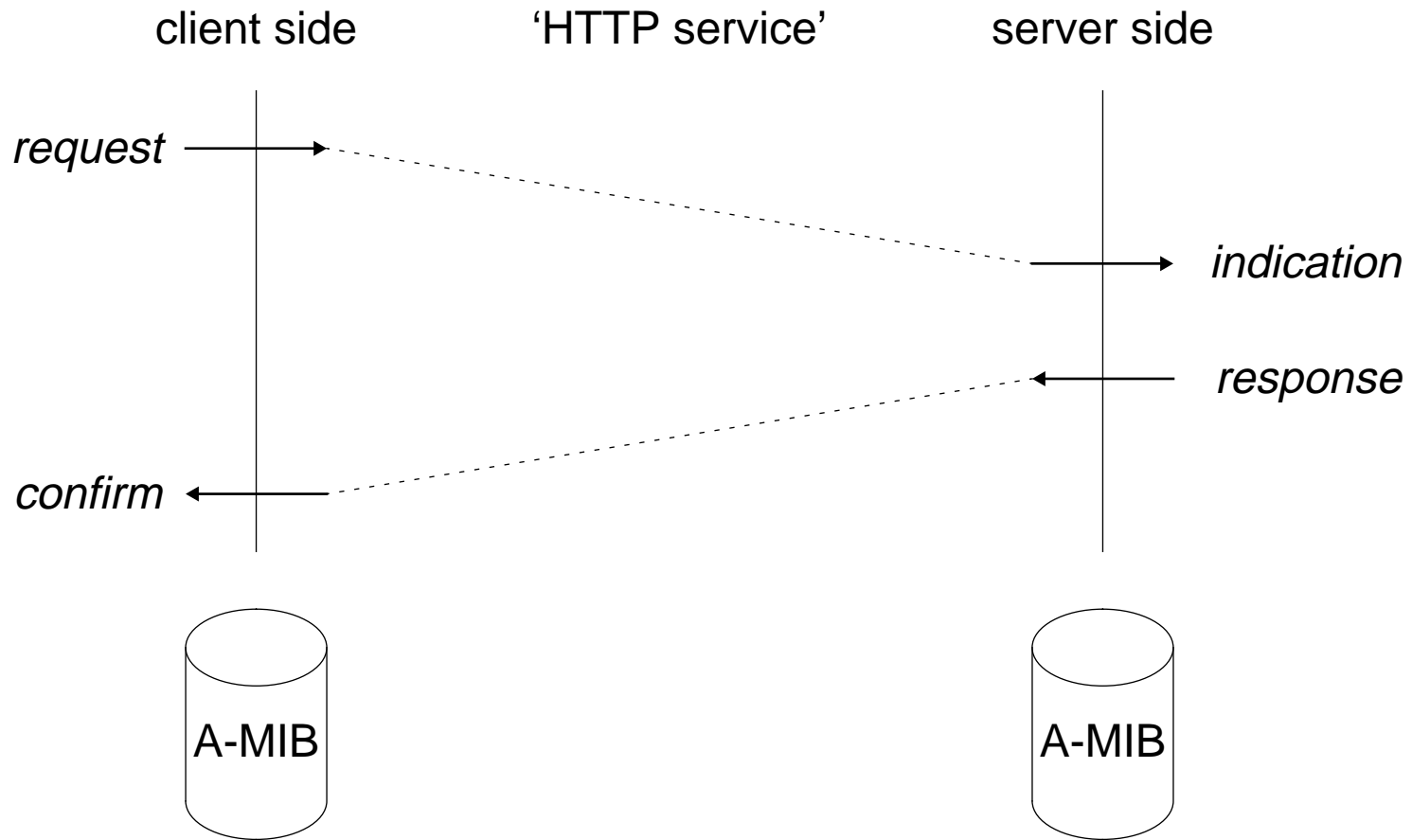

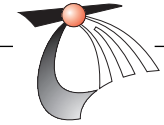

A-MIB

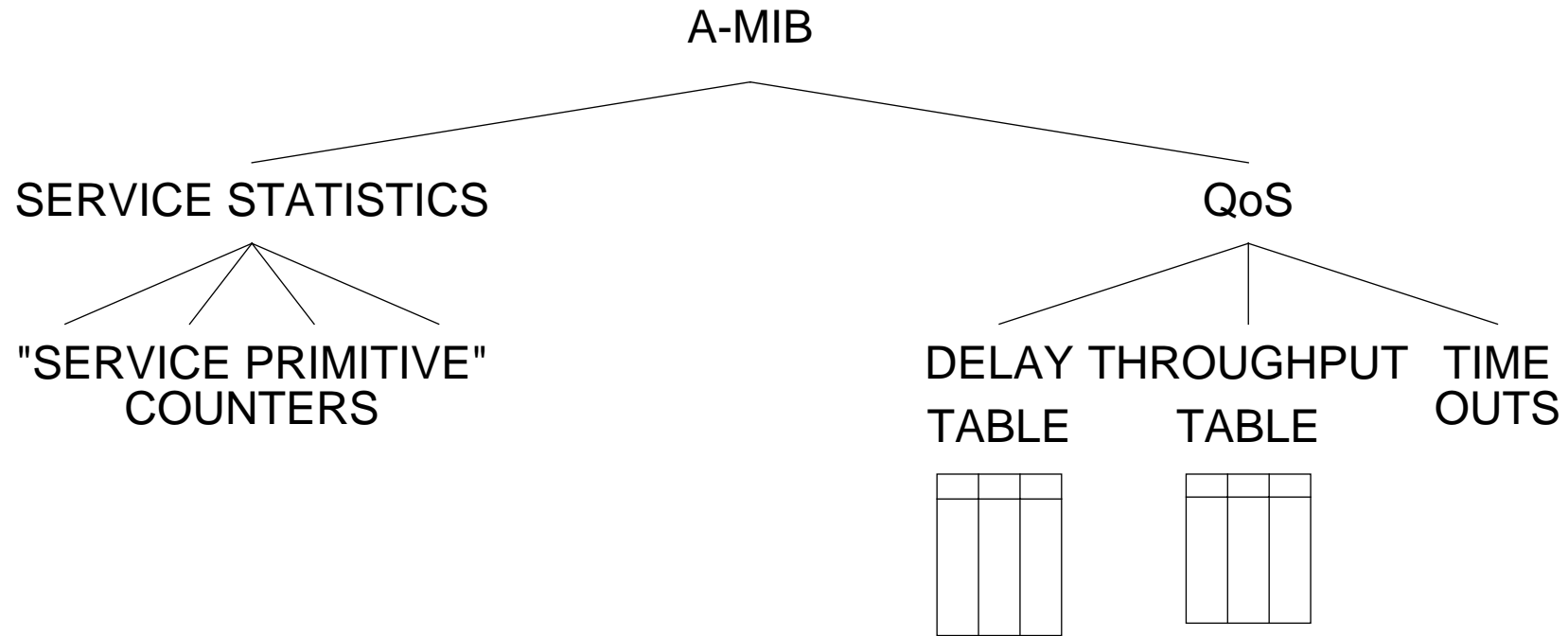

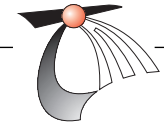

HTTP-MIB

TRAFFIC PATTERN:

- # REQUESTS
- # INDICATIONS
- # RESPONSES
- # CONFIRMS

QUALITY OF SERVICE:

- DELAY PER DESTINATION
- THROUGHPUT PER DESTINATION
 - # TIME-OUTS
 - # ERRORS

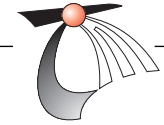

OTHER-MIBS

WWW-SERVER SYSTEM

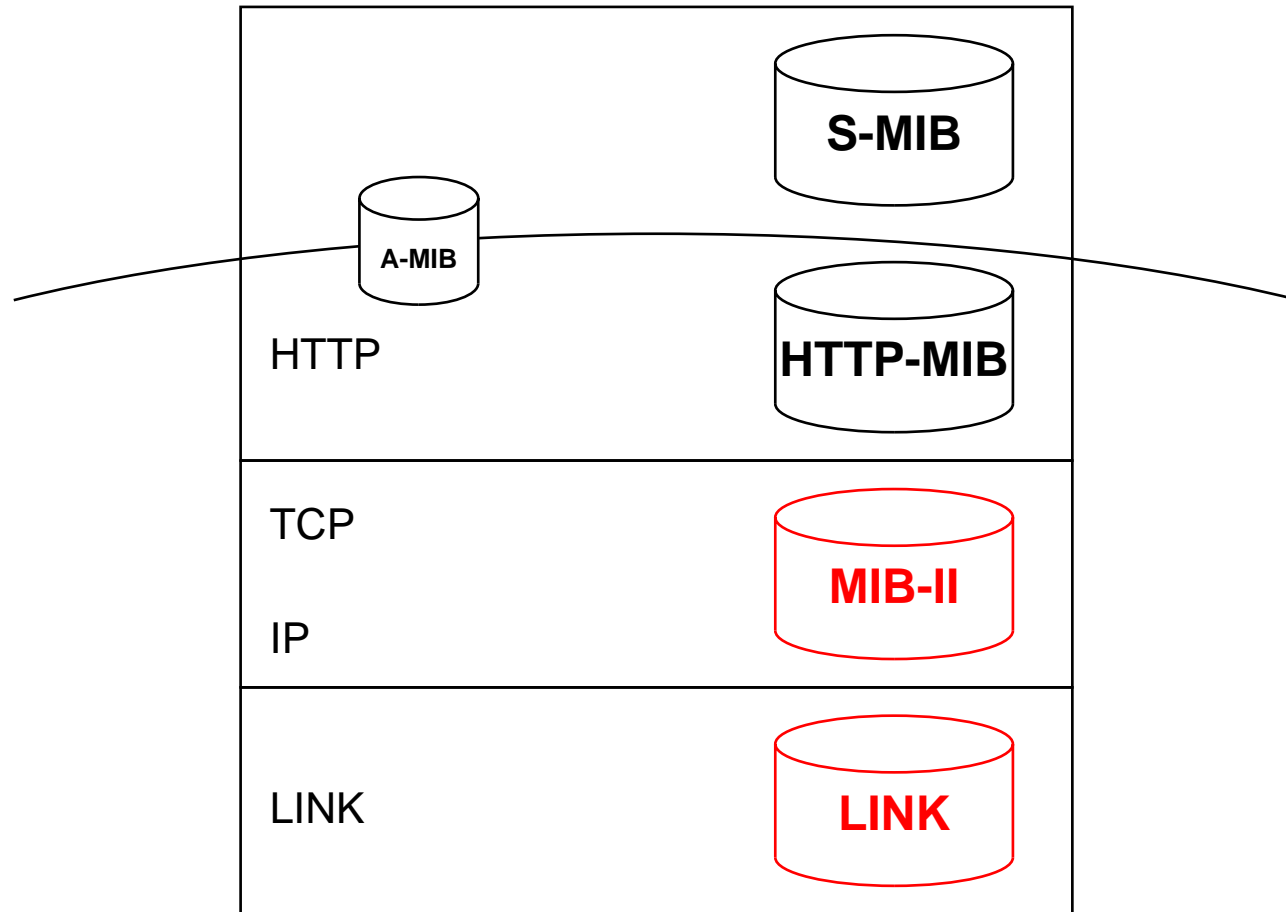

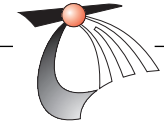

AGENT IMPLEMENTATION

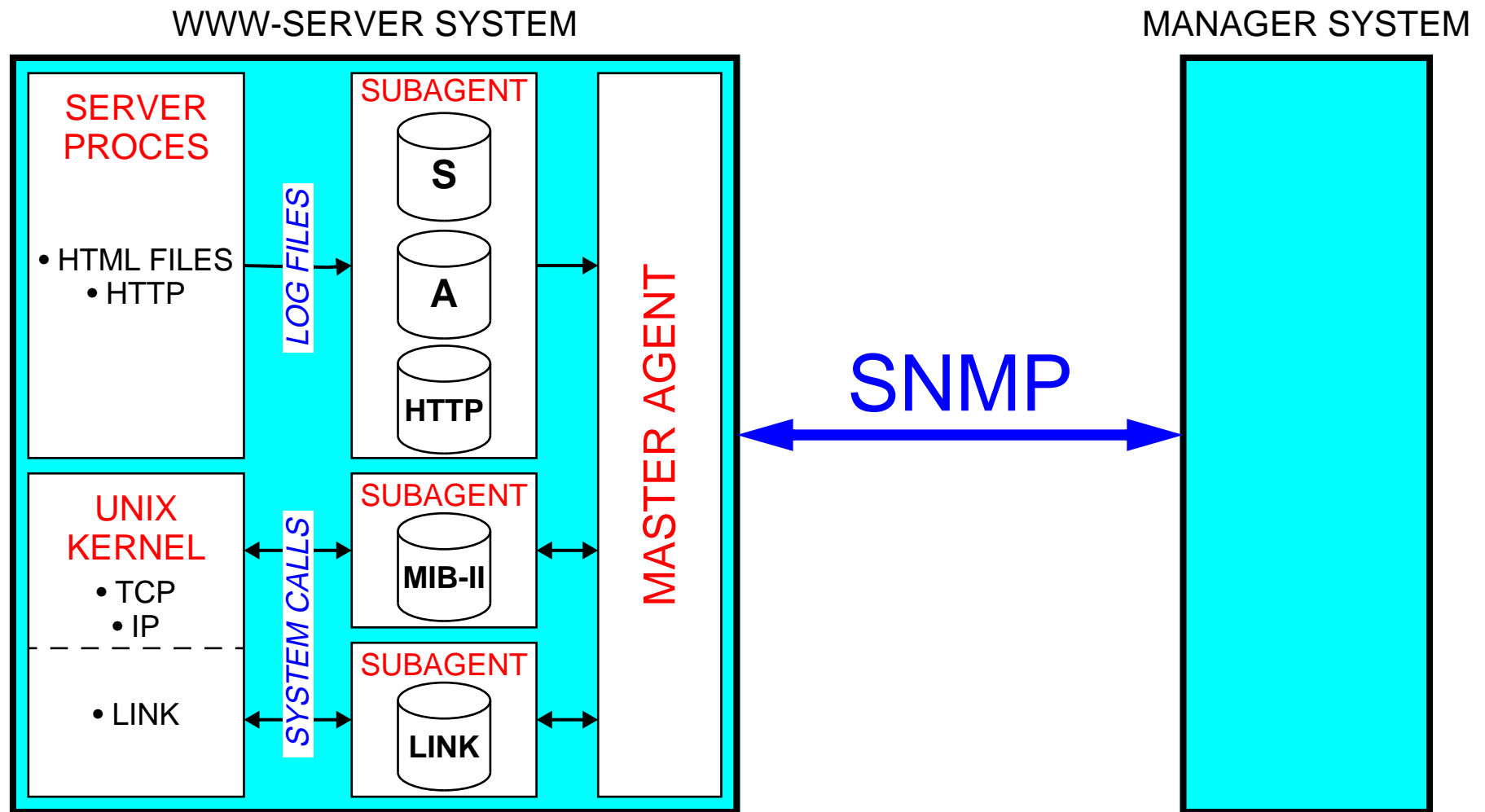

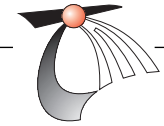

SUBAGENT IMPLEMENTATION

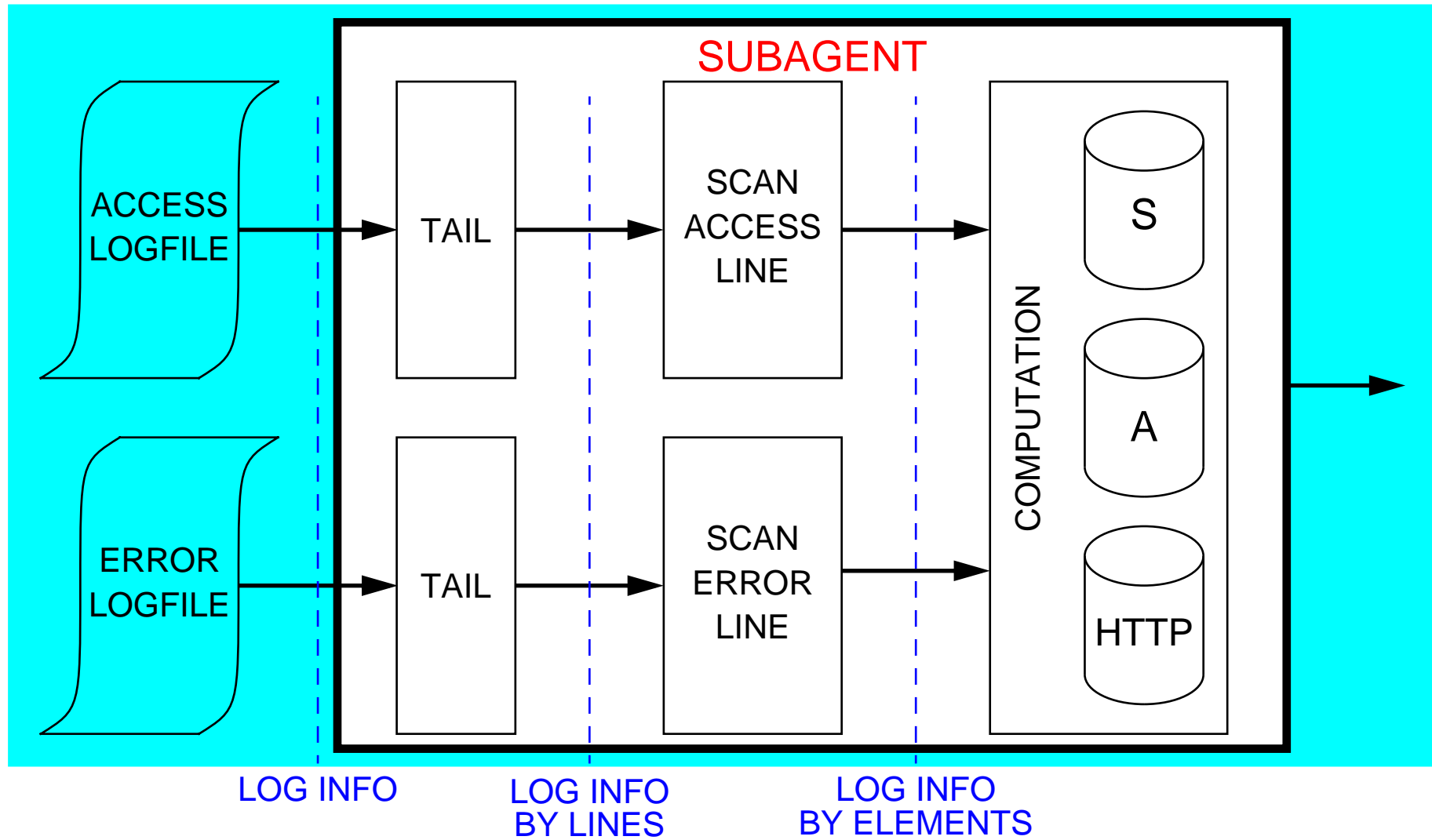

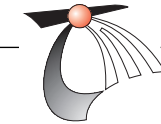

LOGFILES VERSUS IPC

METHOD	ADVANTAGE	DISADVANTAGE
IPC APPROACH	<ul style="list-style-type: none">• COMPLETE CONTROL OVER SERVER (SET OPERATIONS ARE POSSIBLE)	<ul style="list-style-type: none">• SERVER SOFTWARE NEED TO BE MODIFIED
LOGFILE APPROACH	<ul style="list-style-type: none">• NO NEED TO MODIFY SERVER SOFTWARE• CAN BE USED WITH DIFFERENT SERVERS	<ul style="list-style-type: none">• SERVER CAN ONLY BE MONITORED (SET OPERATIONS ARE NOT POSSIBLE)

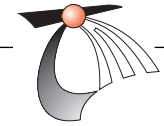

RESULTS

- AGENT HAS BEEN DEMONSTRATED SUCCESSFULLY
- FIRST SNMP BASED WWW-MANAGEMENT SYSTEM IN THE WORLD
 - STANDARDIZATION WITHIN IETF
 - RELATION WITH APPLICATION MIB
 - FOLLOW-UP CONTRACT?
 - NWO - SION?